

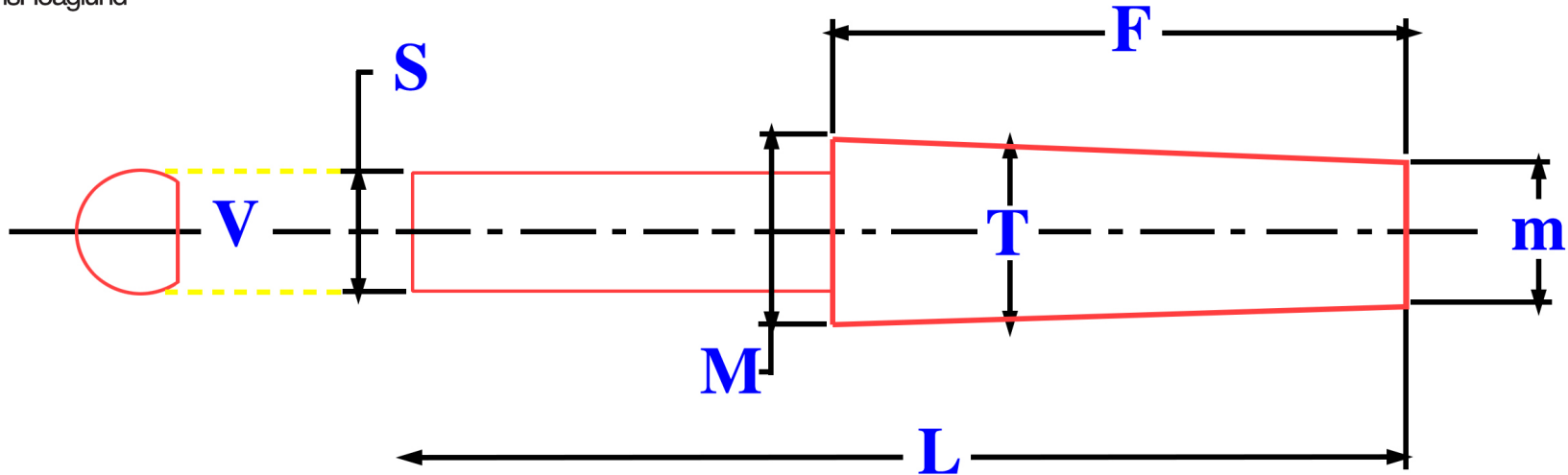

# the GAMMONS<sup>®</sup> Hoaglund Company

## Taper Reamer, Straight Shank

Note:  
These templates are  
not drawn to scale.



**S:** Shank Diameter  
**M:** Major Diameter  
**m:** Minor Diameter  
**F:** Flute Length

**T:** Flute Taper Angle  
**L:** Overall Length  
**V:** # of Flats on Shank  
 (0 through 6)

**Helix:** ✓ one  
 Right  
 Left  
 Straight

**Style:** ✓ one  
 Roughing  
 Finishing

Company Name

Phone Number

Comments

Quantity Needed

Contact

Email Address

Please email or print out  
form and fax it to us

253 Broad Street, Manchester, CT 06040

sales@gammons.com

Phone: 800.842.9446 | 860.432.0252 | 860.646.4483 Fax