

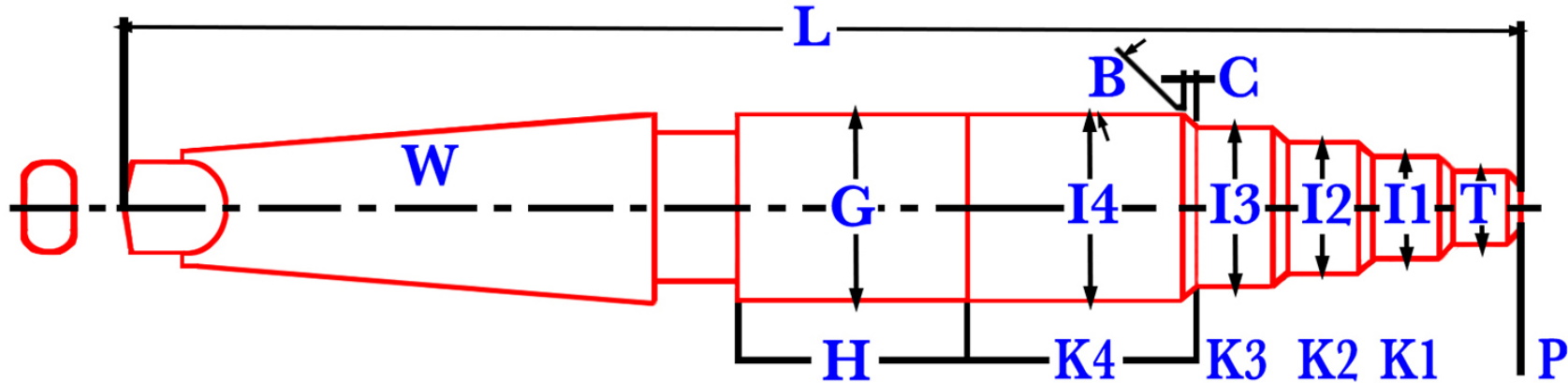

the GAMMONS[®] Hoaglund Company

Step Reamer, Morse Taper Shank

Note:
These templates are
not drawn to scale.



- P:** Pilot Length
- T:** Front Pilot Diameter
- H:** Back Pilot Length
- G:** Back Pilot Diameter
- K1:** Step 1 Length
- K2:** Step 2 Length
- K3:** Step Length 3
- K4:** Step 4 Length
- I1:** Step 1 Diameter
- I2:** Step 2 Diameter
- I3:** Step 3 Diameter
- I4:** Step 4 Diameter
- B:** End Cut Chamfer Angle
(Standard Angle is 45° unless otherwise specified)
- C:** End Cut Chamfer Length
(Same for all steps)
- W:** Shank Size
(#1 through #6)
- L:** Overall Length

- Helix:** ✓ one
- Style:** ✓ one
- Right Roughing
- Left Finishing
- Straight

**Please email or print out
form and fax it to us**

Company Name
Phone Number
Contact
Email Address
Comments

Quantity Needed

*If you require less steps enter zero's for step dimensions. If you require more, please specify (K5, K6, etc...) in the comment section

253 Broad Street, Manchester, CT 06040

sales@gammons.com

Phone: 800.842.9446 | 860.432.0252 | 860.646.4483 Fax